

DWG No	REFERENCES	REV	DATE	DESCRIPTION	DRAWN	CHECK	APPD
1		1	4/12/2011	MOUNTING ANGLE LENGHT REDUCED. CHAIN LENGTH REDUCED.		RCT	
		0	01/09/10	ORIGINAL ISSUE		RCT	

GEARS AND WINCHES
 2 COIN ST MOOROOKA QLD 4105
 PO BOX 206 ACACIA RIDGE QLD 4110
 Ph (07) 3875 1568
 Fx (07) 3277 4316
 Email admin@winch.com.au

COPYRIGHT RESERVED. The design detailed on this drawing is the property of Archerfield Precision Engineering and must be returned on demand. It is issued on the strict condition that excepted to any third party, nor is it to be used for any purpose other than for which it was issued.

DRAWN	RCT	01-09-10	W100 WINCH WITH WORMBRAKE EXPLODED ASSEMBLY PARTS LIST		
CHECKED					
MATERIAL					
MATERIAL NOTES					
FINISH			FOR MANUFACTURE		
DATE PRINTED	WEIGHT	SCALE	SHEET No.	DWG No	-REV
4/12/2011	1090 Kg	1:22	1 OF 2		W100-0012-1

A

B

C

D

E

F

G

H

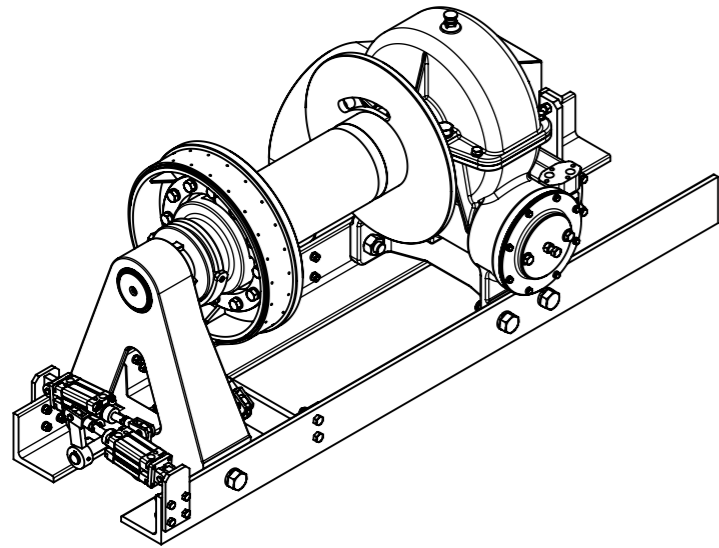
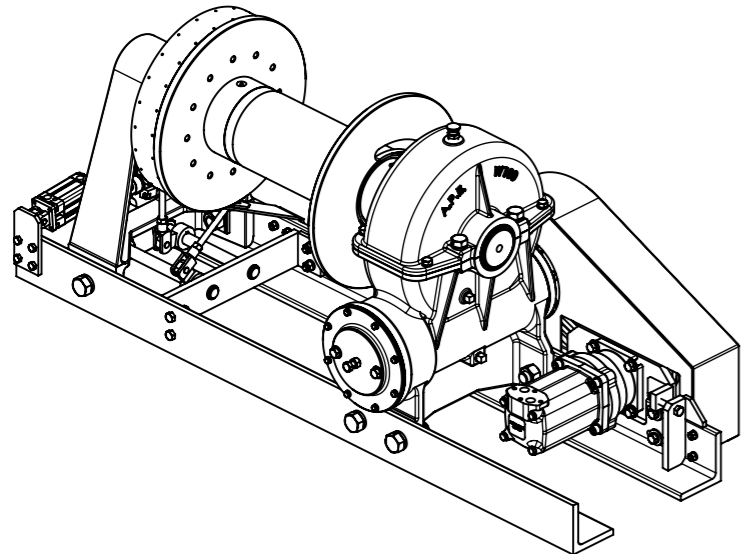

ITEM NO.	QTY.	DESCRIPTION	PART NUMBER	ITEM NO.	QTY.	DESCRIPTION	PART NUMBER
1	1	WORM BOX HOUSING - LOWER HALF	W100-0101	50	4	SP-20 1 1/4 in SHAFT	SP-20
2	1	WORM BOX HOUSING - UPPER HALF	W100-0151	51	1	WORMBRAKE CAP GASKET	W100-0801
3	2	WORMBOX HOUSING BUSH	W100-0700	52	1	WORM SHAFT CAP GASKET	W100-0800
4	1	WORM SHAFT CAP - INPUT END	W100-0200	53	1	KEY ANSI B17.1 0.5x0.5x2	
5	1	WORM SHAFT CAP - INTERNAL	W100-0201	54	1	WORMBRAKE HUB	W100-0750
6	1	END SUPPORT BRACKET	W100-0251	55	1	WORMBRAKE RETAINER	W100-0753
7	1	END BRACKET BUSH	W100-0702	56	1	WORMBRAKE FRICTION DISC	W100-0752
8	1	DRUM SHAFT	W100-0520	57	1	WORMBRAKE CAM	W100-0751
9	1	WORM	W100-0400	58	1	WORMBRAKE CAP	W100-0203
10	1	WORMWHEEL	W100-0420	59	1	WORMBRAKE LEAF SPRING	W100-0754
11	1	WORMWHEEL HUB	W100-0440	60	2	3/4" BEARING BALL	
12	1	WINCH DRUM WELDMENT	W100-0500	61	1	COMPRESSION SPRING	W100-0755
13	2	ROPE CLAMP - TOP PLATE	W100-0509	62	6	HEX NUT 5/8"-11 UNC	HNUT 0.3125-18-D-C-S
14	1	DRUM DOG CLUTCH RING	W100-0600	63	11	HEX HEAD SET SCREW 5/8"-11 UNC x 2 1/2"	HHSS 0.3125-18x0.75
15	2	DRUM BUSH	W100-0701	64	6	5/8" FLAT WASHER	
16	1	DRUM SHAFT SPACER RING	W100-0530	65	1	GUARD WELDMENT	W100-0340
17	1	DOG CLUTCH	W100-0610	66	1	OIL SEAL	CR24982
18	1	DOG CLUTCH YOKE	W100-0270	67	12	HEX HEAD BOLT 3/4"-10 UNC x 3"	HHSS 0.3125-18x0.75
19	1	CLUTCH YOKE PIVOT PIN	W100-0271	68	24	SPRING WASHER 3/4"	
20	1	BASE ANGLE - DRIVE SIDE	W100-0300	69	12	HEX NUT 3/4"-10 UNC	HNUT 0.3125-18-D-C-S
21	1	BASE ANGLE - WORMBRAKE SIDE	W100-0301	70	8	SOCKET HEAD CAP SCREW 5/8"-11 UNC x 1 1/2"	
22	1	WINCH BASE CROSS BRACKET	W100-0320	71	24	SPRING WASHER 5/8"	
23	1	BRAKE BAND ASSEMBLY	W100-0650	72	8	SPRING WASHER 3/8"	
24	1	BRAKE BAND CLAMP PLATE	W100-0656	73	8	HEX HEAD BOLT 3/8"-16 UNC x 1 1/4"	
25	1	BRAKE PULL ROD	W100-0660	74	2	DOWEL PIN 3/8 x 3/4	
26	4	BRAKE SHAFT BUSH	T65	75	4	SPRING WASHER 1"	
27	1	BRAKE CONTROL SHAFT	W100-0621	76	4	HEX HEAD BOLT 1"-12 UNF x 2 3/4"	HHSS 0.3125-18x0.75
28	1	BRAKE AND CLUTCH LEVER ARM	W100-0630	77	4	HEX HEAD BOLT 5/8"-11 UNC x 1 3/4"	HHSS 0.3125-18x0.75
29	2	CYLINDER LEVER ARM	W100-0631	78	2	3/4" BSP SQUARE HEAD PLUG	
30	1	CLUTCH PUSH ROD ASSEMBLY	W100-0640	79	1	BREATHER 3/4" BSPT	
31	1	CLUTCH CONTROL SHAFT	W100-0620	80	19	SPRING WASHER 1/2"	
32	1	BRAKE AND CLUTCH LEVER ARM	W100-0630	81	4	HEX HEAD BOLT 1/2"-13 UNC x 2 1/2"	
33	2	NORGREN CYLINDER PRA/182063/M/50		82	12	HEX HEAD BOLT 3/4"-16 UNF x 2 1/4"	HHSS 0.3125-18x0.75
34	1	MOTOR MOUNT PLATE	W100-0330	83	3	GREASE NIPPLE 1/8" BSP	
35	1	SPROCKET - WORM	W100-0342	84	6	SPRING WASHER 1-1/4"	
36	1	SPROCKET - MOTOR	W100-0341	85	6	HEX HEAD BOLT 1 1/4"-7 UNC x 4"	HHSS 0.3125-18x0.75
37	1	CHAIN	1" BS TRIPLEX x 54 PITCHES	86	6	HEX NUT 1/2"-13 UNC	HNUT 0.3125-18-D-C-S
38	1	DANFOSS MOTOR	OMV 800	87	2	Washer DIN 6918 - 37	
39	1	HYDRAULIC BRAKE	REGGIANA DG-RF/313	88	4	FLAT WASHER WIDE 5/8"	
40	4	M16 SPRING WASHER		89	8	HEX HEAD BOLT 5/8"-11 UNC x 2"	HHSS 0.3125-18x0.75
41	4	M16 x 50 SOCKET HEAD CAP SCREW		90	1	HEX HEAD SET SCREW 5/8"-11 UNC x 4"	HHSS 0.3125-18x0.75
42	2	TIMKEN TAPER ROLLER BEARING	9380 / 9321	91	4	HEX HEAD BOLT 5/8"-11 UNC x 2 1/4"	HHSS 0.3125-18x0.75
43	2	AIR CYLINDER FOOT MOUNT	W100-0670	92	15	HEX NUT 1/2"-13 UNC	HNUT 0.3125-18-D-C-S
44	2	KEY ANSI B17.1 1x1x4.4375		93	11	HEX HEAD BOLT 1/2"-13 UNC x 2"	
45	3	KEY ANSI B17.1 1x1x6.875		94	4	HEX HEAD BOLT 1/2"-20 UNF x 1 1/2"	
46	1	KEY ANSI B17.1 0.625x0.625x2.75		95	4	SOCKET SET SCREW 1/2"-13 UNC x 3/4"	
47	2	KEY ANSI B17.1 0.25x0.25x1.5		96	4	SOCKET SET SCREW 3/8"-16 UNC x 5/8"	
48	4	KEY ANSI B17.1 0.3125x0.3125x1.5					
49	2	SPLIT PIN Ø3.2x36					

DWG No	REFERENCES	REV	DATE	DESCRIPTION	DRAWN	CHECK	APPD
1		1	4/12/2011	MOUNTING ANGLE LENGTH REDUCED. CHAIN LENGTH REDUCED.		RCT	
		0	01/09/10	ORIGINAL ISSUE		RCT	

GEARS AND WINCHES
 2 COIN ST MOOROOKA QLD 4105
 PO BOX 206 ACACIA RIDGE QLD 4110
 Ph (07) 3875 1568
 Fx (07) 3277 4316
 Email admin@winch.com.au

COPYRIGHT RESERVED. The design detailed on this drawing is the property of Archerfield Precision Engineering and must be returned on demand. It is issued on the strict condition that except with our written permission it must not be copied or communicated to any third party, nor is it to be used for any purpose other than for which it was issued.

DRAWN	RCT	01-09-10	W100 WINCH WITH WORMBRAKE EXPLODED ASSEMBLY PARTS LIST		
CHECKED					
MATERIAL					
MATERIAL NOTES					
FINISH			FOR MANUFACTURE		
DATE PRINTED	WEIGHT	SCALE	SHEET No.	DWG No	-REV
4/12/2011	1090 Kg	1:20	2 OF 2	W100-0012-1	