

HYDRAULIC W10-600 BASE MOUNT WINCH

A compact, versatile, heavy duty winch mounted in a rugged frame. Ideal for:

- Recovery
- Tilt trays and slide backs
- Telecommunications
- Mine Sites
- Logging
- Tractors



**PROUDLY MADE IN
AUSTRALIA
FULL 2 YEAR WARRANTY**

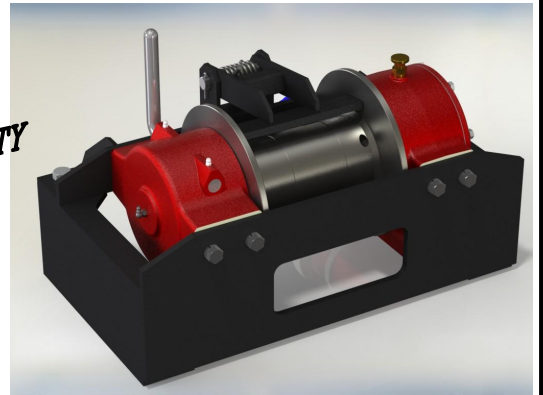

Hydraulic drive.

Lever operated dog clutch with optional pneumatic cylinder operation.

Large drum diameter to extend rope life.

Drag brake on the drum to prevent wire rope ballooning when freewheeling.

We can produce custom designs if the standard winch just won't do.

SPECIFICATIONS

Capacity: 44.5 kN (10,000 lb)

Weight: 67kg (without rope)

Ratio: 38:1

Rec. Wire Rope: 30m x Ø10mm

Max Wire Rope: 67m x Ø10mm

Hydraulic Oil Requirements

75 litre/min @ 130 bar

Layer	Line Pull kN	Line Speed @ 75 l/m m/min	Line Speed @ 60 l/m m/min	Total rope Length m
1	44.5	8.5	6.8	8.0
2	38.3	9.9	7.9	17.3
3	33.6	11.3	9.0	28.0
4	30.0	12.8	10.2	39.9
5	27.0	14.2	11.4	53.1
6	24.6	16.2	12.9	67.6



All our winches feature hardened and ground worms and bronze worm wheels for long service and reliability.

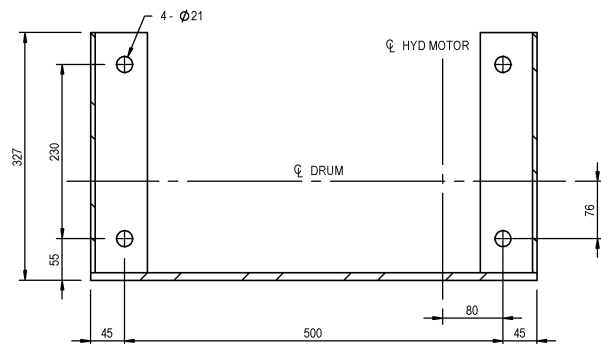
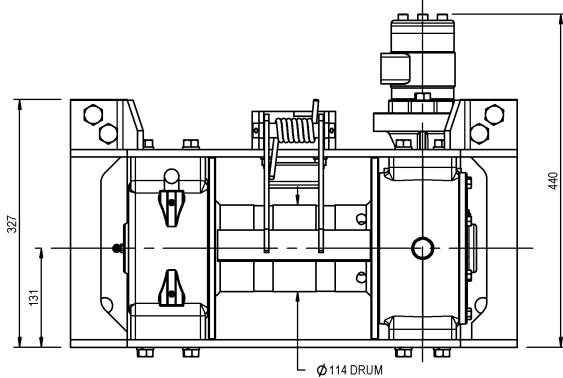

SECTION A-A
HOLD DOWN DETAIL

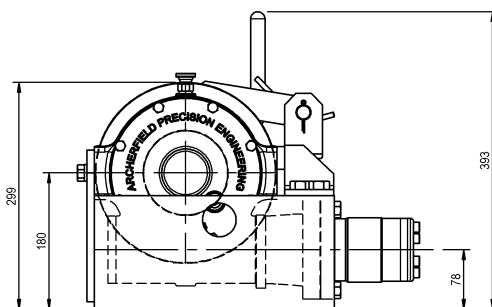
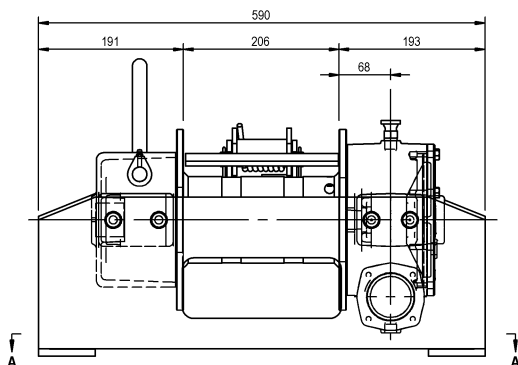

Your Winch Distributor is:

**GEARS AND
WINCHES**

GEARS AND WINCHES

A registered trading name of
Winch Industries Pty Ltd
2 Coin Street
Moorooka Qld 4105
Ph: (07) 3875 1568
Fx: (07) 3277 4316
www.winch.com.au